

1977 CHEVROLET BLAZER



- Permanent metal roof over driver and right-hand front passenger area
- Removable fiberglass-reinforced plastic top over rear area available with either white or black textured exterior paint finish
- Soft, vinyl-coated fabric convertible top available in black, white, blue or buckskin.

- Both tops include two large side windows
- Three interior lamps, coat hooks front and rear, tailgate with roll-up window (removable plastic top only)

1977 CHEVROLET BLAZER VALUE FEATURES

NEW FOR 1977

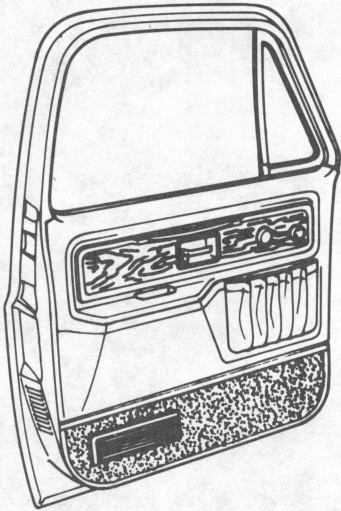

Door trim panels now cover a greater area of the door.

Blazers with Cheyenne trim level will retain the map pocket.

New seat trim features new patterns and colors. See page 16 for more information.

Blazer soft-top is available in four colors: White, Black, Blue and Buckskin.

Heavy-duty front springs now require heavy-duty front and rear shock absorbers. Capacity of the heavy-duty springs for K10 models is increased from 1900 to 2250 lbs. each.

Wood-grain applique used on interior trim has a new simulated chestnut appearance.

New paint colors and trims for both exterior and interior are highlighted on page 16.

New improved ignition lock and retainer for theft protection plus new key combinations.

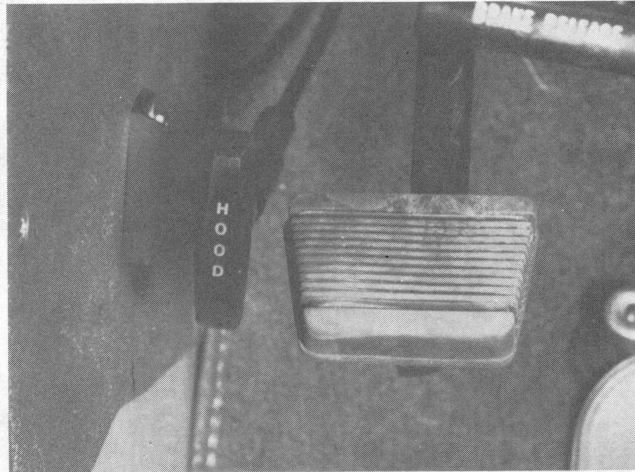

Other new options:

- Color-keyed floor mats.
- Intermittent windshield wiper system.
- Inside hood release latch.

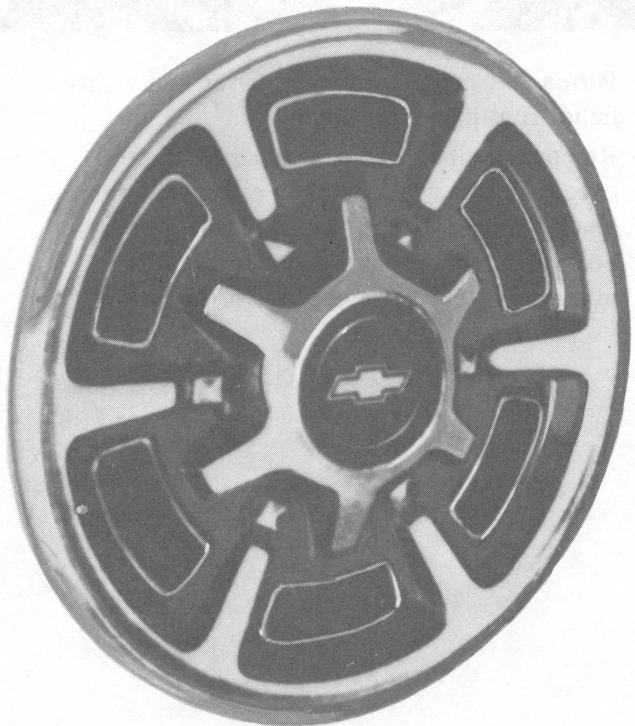

New wheel trim options are available for C/K10 models • A new full black and gray, stainless steel wheel cover in a spoked hub design is available • New optional white-painted wheel features a spoke-type design.

Shock absorbers • New optional 32mm shock absorbers available for 4-wheel-drive models in conjunction with heavy-duty front springs.

1977 CHEVROLET BLAZER VALUE FEATURES

NEW FOR 1977

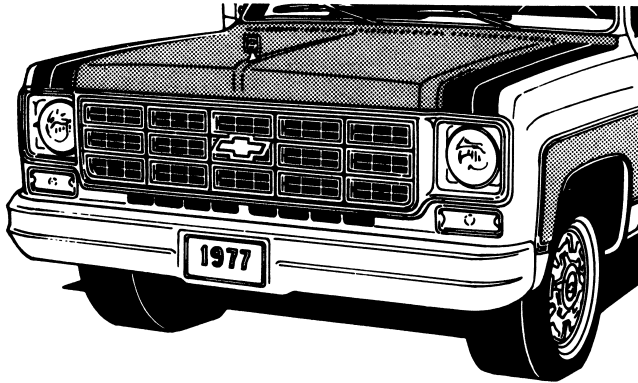

New front end appearance features a redesigned grille • Headlamp bezels now dark gray metallic.

Body side moldings for Cheyenne and molding packages have new ochre paint trim.

New front compartment headliner is available separately or as a part of Cheyenne trim package and is of hardboard-backed foam rubber with perforated Light Fawn vinyl skin • Interior color of standard hardtop is now Light Fawn.

Available rear speaker is located in the right-hand rear trim panel. (Requires Cheyenne equipment.)

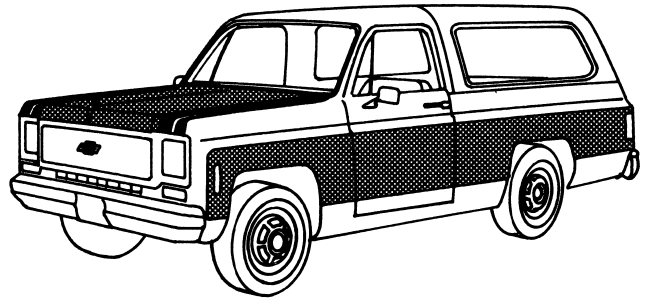

New Exterior Decor Package for either hard-top or soft-top Blazers features special two-tone paint treatment which uses the secondary color on the hood and between upper and lower body side moldings. Also includes color-coordinated hood stripes and a bright stand-up-type hood emblem, Available only on Blazers with white tops. See page 16 for color availability.

1977 CHEVROLET BLAZER MODELS

BLAZER

HARDTOP—2 WHEEL DRIVE

Series	Model Number	Body Code	GVWR Range	Payload Range
C10	C10516	White top Z58 Black top Z59	6050	1960

HARDTOP—4 WHEEL DRIVE

Series	Model Number	Body Code	GVWR Range	Payload Range
K10	K10516	White top Z58 Black top Z59	6200	1756

CONVERTIBLE—2 WHEEL DRIVE

Series	Model Number	Body Code	GVWR Range	Payload Range
C10	C10516	White top C1A Black top C1B Blue top C1C Buckskin top C1D	6050	2010

CONVERTIBLE—4 WHEEL DRIVE

Series	Model Number	Body Code	GVWR Range	Payload Range
K10	K10516	White top C1A Black top C1B Blue top C1C Buckskin top C1D	6200	1806

1977 CHEVROLET BLAZER CONVERTIBLE



TOP UP • Top is made with vinyl-coated fabric, Zepel®-treated and stain- and mildew-resistant for a neat, trim appearance and snug comfort inside

- Windows are quality clear vinyl, dielectrically and permanently sealed to fabric.



INTERMEDIATE SAFARI POSITION • Lets the breezes in and still provides protection from the sun • Long-lasting nylon thread stitching and Scotchmate® fasteners used throughout.



TOP DOWN • Blazer becomes an open air vehicle with the convertible top in the full-down position

- All attaching parts fold with the top . . . no lost pieces
- With the top down, Blazer's cargo area can accommodate large, bulky loads.

1977 CHEVROLET BLAZER CHALET



THE BLAZER YOU CAN LIVE IN.

Blazer Chalet combines the toughness of a 4-wheel-drive Chevy Blazer with the advantages of a camper unit.

Camper has a fiberglass-reinforced plastic body over a steel frame and is mounted permanently on the Blazer.

- Camper and Blazer are bolted together for strength.
- A unique rubber seal between the camper and Blazer's steel half top flexes to allow for normal sway and to keep out air and moisture.
- Camper top pops up easily to provide more than six feet of head room.
- Unit is fully integrated, allowing direct access from the cab back to the living quarters.

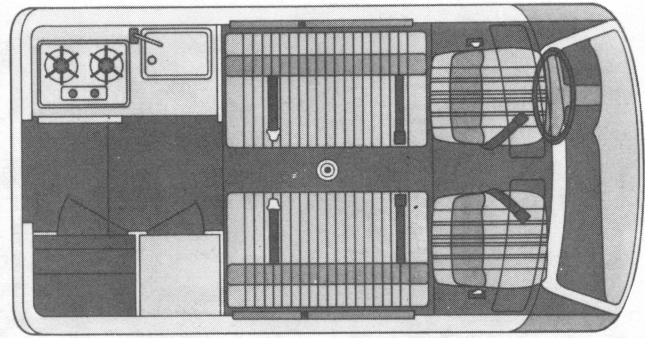

Blazer Chalet is available in four versions: Base Package and Packages A, B and C.

Base Package:

- Convertible seat/bunks can provide seating for four adults and sleeping accommodations for two.
- Demountable dinette table with ample leg room fits between the seats.
- Seats are upholstered in saddle vinyl to coordinate with cab seats.
- Galley is equipped with a stainless steel sink and drain.
- Five-gallon water supply tank with electric pump and convenient outside fill faucet.
- Two-burner LPG stove with a stainless steel top and painted vent hood.
- Ice box and spice rack.
- Five-gallon LPG tank.
- All camper windows have tinted glass.
- All windows and the cab opening have either color-keyed curtains or drapes.
- Floor and overhead area are covered with indoor-outdoor carpeting.
- Walls are covered with padded vinyl.
- A snap-on padded vinyl cover is provided for the cab-camper joint.
- Two roomy storage compartments, one equipped with a hanging wardrobe.



1977 CHEVROLET BLAZER CHALET

Package A:

This package includes all items in the Base Package with the addition of a 5000 BTU LPG heater.

Package B:

All items in the Base Package and Package A are included in Package B with the exception of the ice box. In Package B, a 3-way refrigerator replaces the ice box. Refrigerator can be run with LPG, battery or AC-DC hookup. Included with the refrigerator is an electrical power hook-up package (with battery) and an AC power hook-up kit with AC-DC converter.

Package C:

This package includes everything offered in the Base Package and Packages A and B plus two overhead bunks, so that Blazer Chalet can sleep four.

The Blazer that comes with all Chalet packages is specially equipped.

Equipment includes:

- Power steering.
- L78-15D (8PR) blackwall tires.
- Front auxiliary bucket seat.
- Deluxe chromed front and rear bumpers.
- Front-mounted spare tire carrier.
- 350 4-bbl. V8 engine is standard. 400 4-bbl. available.
- One of two available 4-wheel drive systems can be specified: Conventional system is included with the standard 3-speed or available 4-speed manual transmissions • Full-time 4-wheel drive is included with available Turbo Hydra-matic transmission.

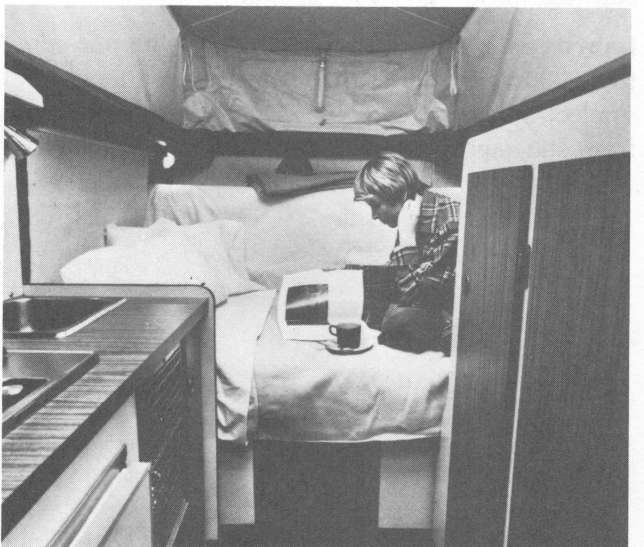

1977 CHEVROLET BLAZER ENGINE VALUE FEATURES

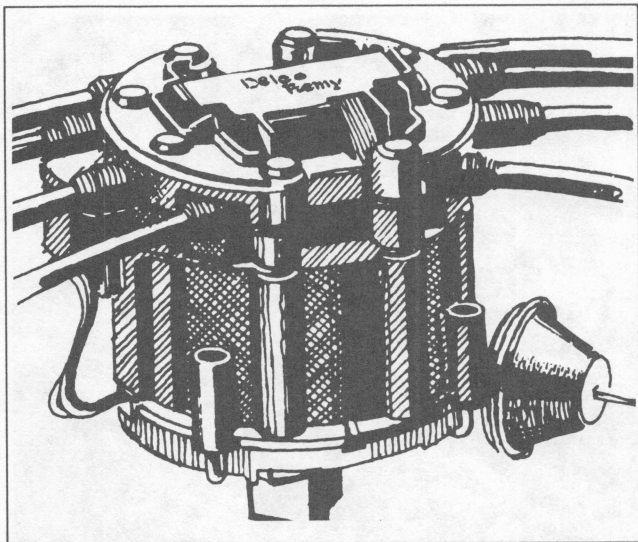

High Energy Ignition system • Magnetic pulse generator, electronic control module replace points, condenser and rubbing block • Coil designed for 85% hotter spark than conventional systems.

Reduces periodic ignition maintenance

• Solid-state design eliminates cost of replacing points, condenser.

Extends spark plug life • Fires burned or eroded plugs • Reduces cost of frequent plug replacement.

Improves cold-weather starting • Fires marginal mixtures • Quick starts help reduce battery drain.

Provides all-weather protection • Shrugs off moisture, road splash • Helps eliminate hard starting, misfiring in cold or damp weather.

Improves ignition performance • Supplies up to 35,000 volts—more than other conventional or electronic systems • Effective under all conditions from starting to turnpike cruising.

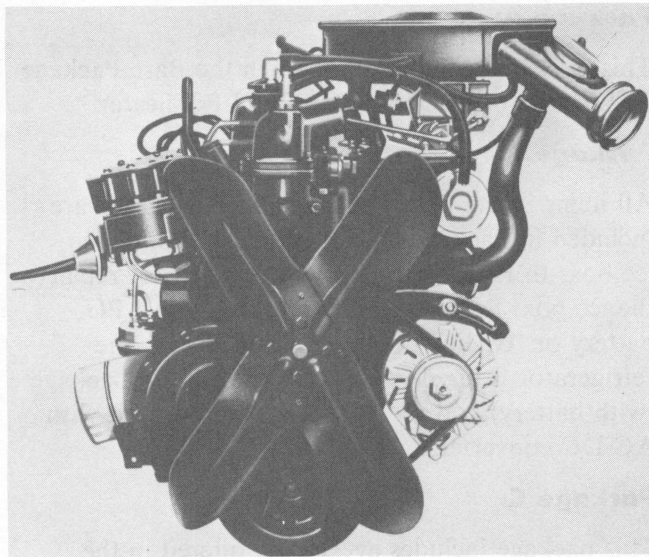

Efficient 250 6-cylinder engine

• Standard on Blazers • Uses no-lead or regular fuel • Compression ratio is 8.0:1 • Features 7 main bearings for durability, 12-counterweight crankshaft and torsional dampeners for smoothness • Single-barrel carburetor is easy to service.

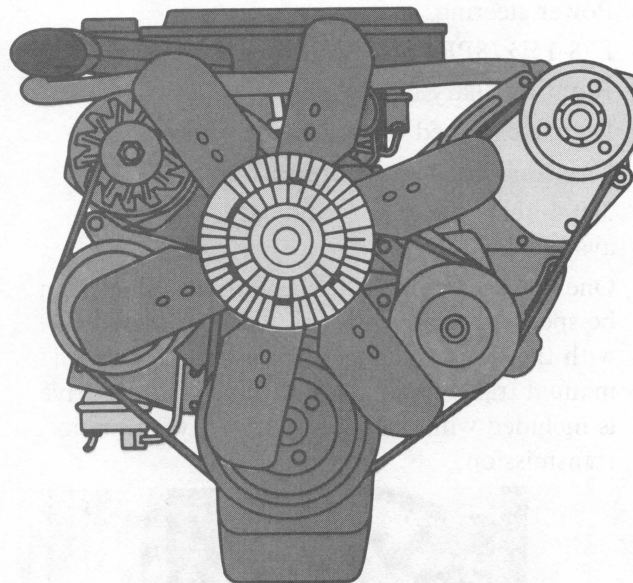

New 305-2 V8 • Available on K10 Blazers.

305-2 V8 • Available on all Blazers (350 4-barrel specified in California). Like all Chevy V8s, it has short-stroke design and full-jacket cylinder cooling.

350-4 V8 • Available on C-K10 Blazers.

350-4 V8 • For increased torque and horsepower • Performs efficiently on no-lead or regular fuel • Available on all Blazers.

400-4 V8 available in K models • For Blazers with automatic transmission • Large displacement for heavy loads, difficult terrain, trailer towing.

1977 CHEVROLET BLAZER POWER TEAMS

ENGINE	TRANSMISSION	TRANSFER CASE		REAR AXLE
Type and Code	Type and Code	Make and Model	Make and Capacity (lb)	Ratio and Code

C10 SERIES

				3.07 HE3	3.73 GT4	4.11 HO4
● 250 1-bbl L6—LD4 (Standard Engine)	3-Speed Manual (Std)—M15	—	Chevrolet 3750	—	—	◆X(Std)
	4-Speed (Chevrolet CH465)—M20			—	X(Std)	◆X
	Turbo Hydra-matic—M40			—	X(Std)	◆X
● 305 2-bbl V8—LG9	3-Speed Manual (Std)—M15			X(Std)	X	◆X
	4-Speed Manual (CH465)—M20			X(Std)	X	◆X
	Turbo Hydra-matic—M40			X(Std)	X	◆X
■ 350 4-bbl V8—LS9	3-Speed Manual (Std)—M15			X(Std)	X	◆X
	4-Speed (Chevrolet CH465)—M20			X(Std)	X	◆X
	Turbo Hydra-matic—M40			X(Std)	X	◆X

K10 SERIES

				3.07 HE3	3.73 GT4	4.11 HO4
● 250 1-bbl L6—LD4 Standard Engine)	3-Speed Manual (Std)—MC1 a	New Process #205	Chevrolet 3750 ◆	—	—	X(Std)
	4-Speed (Chevrolet CH465)—M20			—	X(Std)	X
	Turbo Hydra-matic—M40			—	X(Std)	X
● 305 2-bbl V8—LG9	3-Speed Manual (Std)—MC1	New Process #205		—	X(Std)	X
	4-Speed Manual (CH465)—M20			X(Std)	X	X
	Turbo Hydra-matic—M40			X(Std)	X	X
■ 350 4-bbl V8—LS9	3-Speed Manual (Std)—M15	New Process #205		X(Std)	X	X
	4-Speed (Chevrolet CH465)—M20			X(Std)	X	X
	Turbo Hydra-matic—M40			X(Std)	X	X
■ 400 4-bbl V8—LF4	Turbo Hydra-matic—M40	New Process #203	X(Std)	X	—	

- Available for registration in the State of California when California Emission Certification is ordered.
- Not available for registration in the State of California.
- ◆ Locking Differential rear axle also available.
- a Not recommended for GVW of 6200 lb.

ENGINE RATINGS

Engine ratings shown are not official at this time, and are for guide purposes only

SAE Net Ratings @ 85°F	250 1-bbl L6	305 2-bbl V8	350 4-bbl V8	400 4-bbl V8
Net Horsepower	100 @ 3600 rpm	140 @ 3800 rpm	165 @ 3800 rpm	175 @ 3600 rpm
Net Torque, lb-ft.....	175 @ 1800 rpm	245 @ 2000 rpm	255 @ 2800 rpm	290 @ 2800 rpm

1977 CHEVROLET BLAZER POPULAR OPTIONS

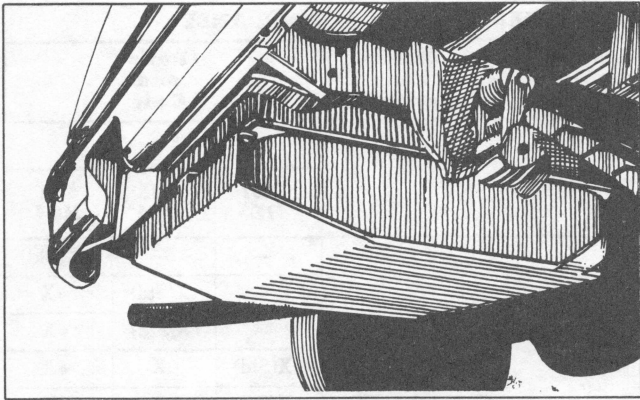

Shield plates • Help protect fuel tank over rough terrain • Include transfer case shield plate.

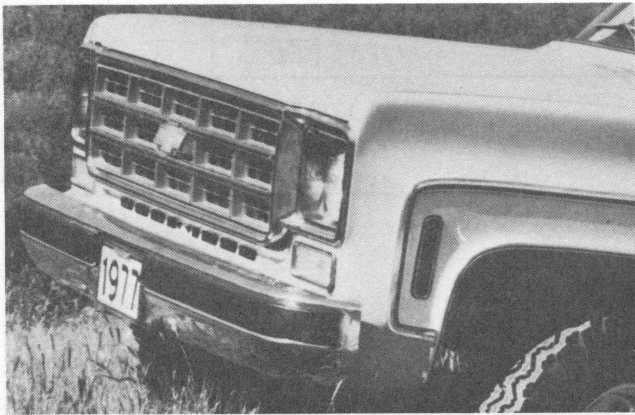

Deluxe chromed bumpers • Include black rubber impact strip.

Convenient spare-tire mounting • Located on right-hand side panel • Tires accessible from curb side.

Special two-tone exterior • Area between included upper and lower body side and tailgate moldings painted Frost White • Not available with black top.

New Exterior Decor Package • For either Hard-Top or Soft-Top Blazers • Features special 2-tone paint treatment which uses the secondary color on the hood and between upper and lower body side moldings • Also includes color-coordinated hood stripes and a bright stand-up-type hood emblem • Available only on Blazers with white tops • See page 16 for color availability.

Simulated wood-grain exterior • Redwood-grain vinyl appliques between upper and lower body side and tailgate moldings • Available with either white or black hardtop and all solid exterior colors • Moldings are included.

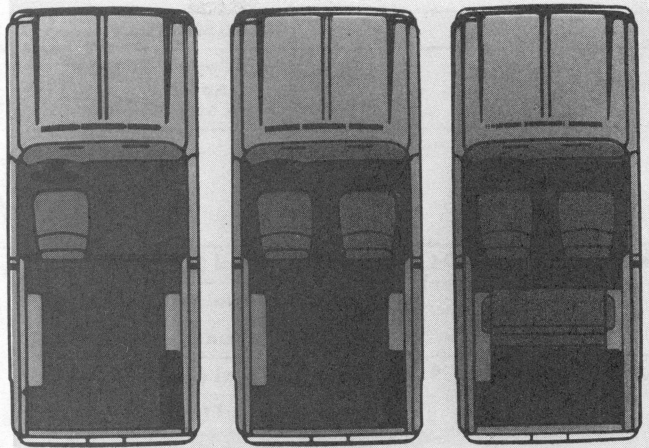

Seating available for up to five • Driver's bucket seat standard • Auxiliary passenger bucket seat available with Custom Deluxe Blazer, included with Cheyenne trim package • Full-width rear bench seat available for both Custom Deluxe and Cheyenne Blazers.

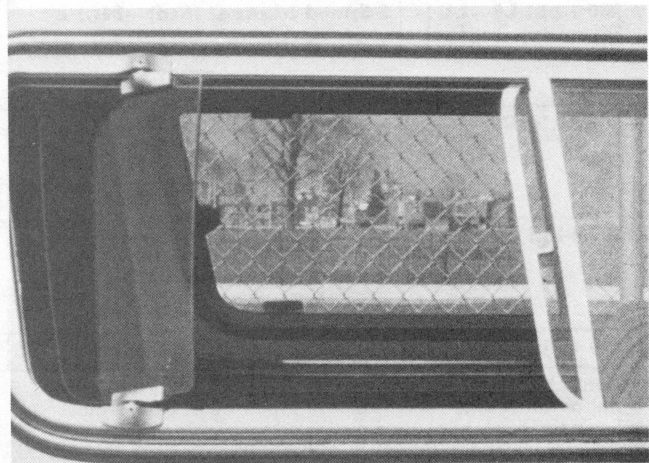

Sliding side window glass • Available with removable plastic hardtop • Replaces fixed side window glass • Improves rear compartment ventilation • Windows have adjustable outboard ventipane sections to control incoming air flow.

Other popular options:

- Side spear molding
- Chromed grille
- Chromed bumpers
- Front bumper guards
- Door-edge guards
- Front towing device.
- New heavy-duty 32MM shock absorbers.

1977 CHEVROLET BLAZER POPULAR OPTIONS

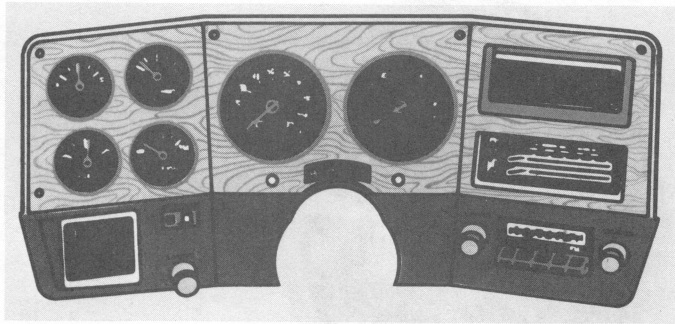

Gauge-type instrument cluster • Provides voltmeter, oil pressure and temperature gauges
• Tachometer or clock available separately
• Wood-grain vinyl trimmed face plate available.

AM or AM/FM radio • Fully transistorized • Low battery drain • Antenna embedded in windshield glass when radio is factory installed • New rear-mounted speaker available.

New chestnut wood-grained vinyl instrument panel • Available when full-gauge instrumentation is specified • Included with Cheyenne option.

Soft-Ray tinted glass • Filters out 50% of sun's heat rays • Reduces inside temperatures • Increases effectiveness and efficiency of available air conditioning • Available all around (removable top only) or for windshield only.

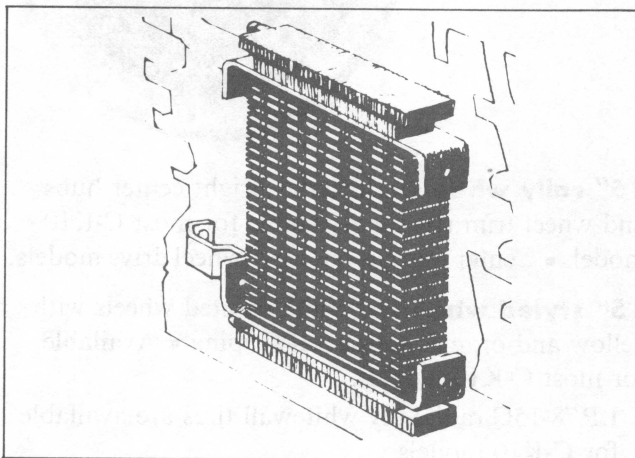

Engine oil cooler • Supplements normal cooling through oil sump and engine block • Recommended for heavy-duty trailering • Available only with V8s.

All Weather air conditioning • Makes Blazer a comfortable place even on hot days • Includes increased capacity radiator • Also includes 61-amp Delcotron generator.

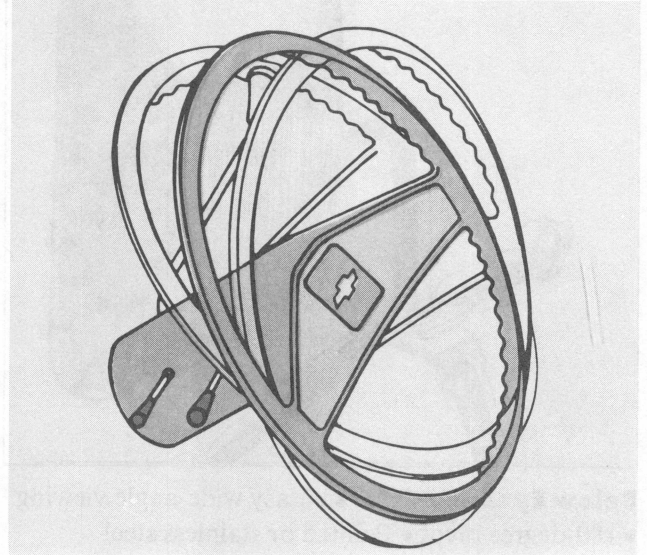

Comfortilt steering wheel • Adjusts to six positions • Available only with 4-speed or automatic transmission.

Variable-ratio power steering • Improves maneuverability • Eases parking • Reduces steering effort on or off the road.

Speed and Cruise Control • Holds vehicle speed constant over any terrain • Pushbutton setting, instant release when brakes are applied • Helps save fuel wasted by constant changes in throttle opening.

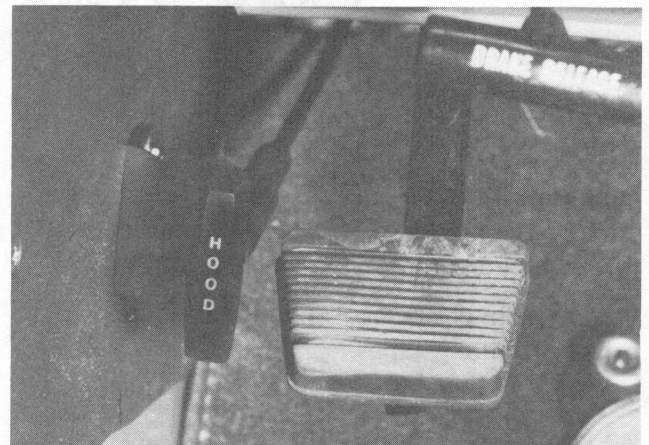

New inside hood latch release • Available for all Blazers • Release handle is on left-hand kick panel beneath instrument panel • Helps prevent theft of underhood items.

1977 CHEVROLET BLAZER POPULAR OPTIONS

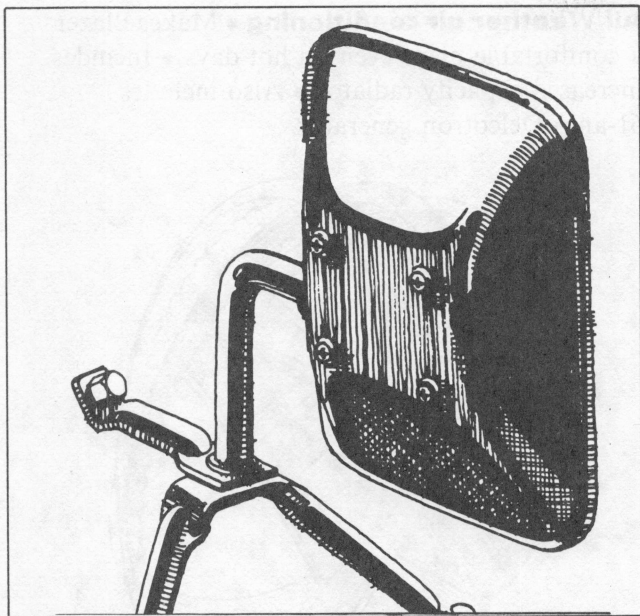

Below Eyeline mirrors • Easy wide-angle viewing
• 180-degree pivot • Painted or stainless steel
• Camper-type stainless steel or painted mirrors with adjustable arm also available for use with trailers up to 96" wide.

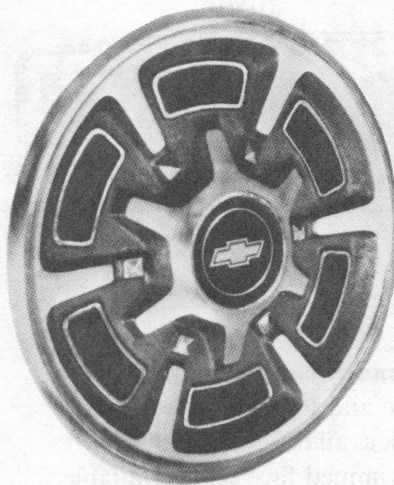

Full wheel covers—bright metal • Completely new design • Center cut out for 4-wheel-drive models.

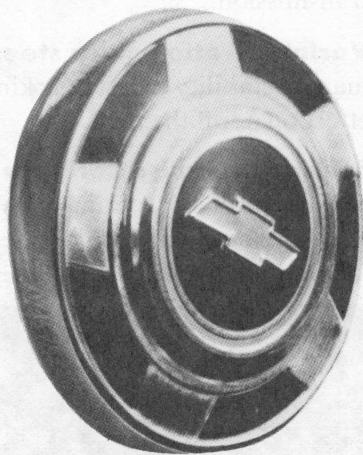

Hub caps—bright metal • Bright with black paint trim • 5-spoke 10" design • Center cut out for 4-wheel drive models.

Wheel trim rings—bright metal • Requires bright metal hub caps

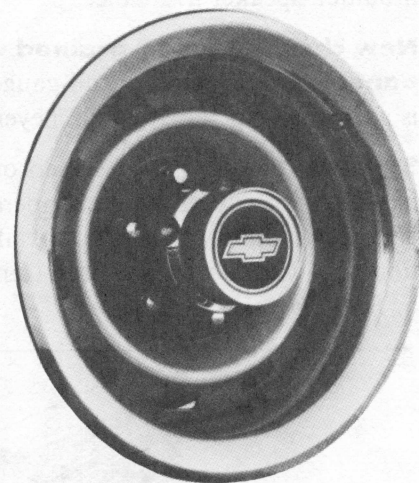

15" rally wheels • Includes bright center hubs and wheel trim rings • Available for most C-K10 models • Center hub cut out for 4-wheel drive models.

15" styled wheels • White painted wheels with yellow and orange peripheral striping • Available for most C-K10 models.

• LR78-15C radial ply whitewall tires are available for C-K10 models.

1977 CHEVROLET BLAZER TRAILERING PACKAGE



Trailer Special Package available for C10 and K10 Blazers. Includes:

- HD Delco Freedom battery
- Power steering
- Trailering Special emblem.

(Requires V8 engine, 61-amp generator and heavy-duty radiator or air conditioning)

Trailering hitches available • Deadweight-type for trailers under 2000 lbs. • Weight-distribution

platform for trailers over 2000 lbs. • Both are factory installed.

Trailering wiring harness available • Heavy-duty 7-wire harness • Includes electric trailer brake connections.

31-gallon fuel tank • Extra capacity for long trips, off-road excursions • Frame-mounted behind rear axle • Replaces 25-gallon standard tank.

†GCWR in Pounds by Axle Ratio		8000	8500	9000	9500	10,500
Tires, Front & Rear	C-K10	H78-15B				
Transmission	C-K10	Turbo Hydra-matic (all engines) or 4-Speed (350 V8 only)				
Engine: 350-4 V8	C-K10	3.07			3.73	4.11*
400-4 V8	K10		3.07			3.73
GCW Shown on Trailering Special Nameplate		8000				10,000

*Not available on K models.

†GCWR: Gross combined weight rating of vehicle, trailer, cargo and occupants

1977 CHEVROLET BLAZER CUSTOM DELUXE TRIM LEVEL



Standard Custom Deluxe interior includes:

- Foam-padded vinyl-trimmed driver's bucket seat in four color choices
- Color-keyed instrument panel pad, sun visor and armrests
- Courtesy lamp
- Padded sun shades
- Two dome lamps
- Rear compartment coat hooks

- Molded plastic door trim panels
- Black rubber front and rear floor mats
- Prismatic rearview mirror.

Front driver and passenger bucket seats

- Available Cheyenne-level vinyl trim plus a center console
- Includes color-keyed front carpeting.



Standard Custom Deluxe exterior includes:

- Bright upper and lower grille outline moldings
- Bright headlamp bezels with dark gray paint trim
- Bright outside rearview mirrors
- White painted bumpers and wheels
- White painted hubcaps with black and ochre trim (except 4-wheel-drive models)
- Bright Blazer nameplates
- Bright Chevrolet tailgate nameplate

1977 CHEVROLET BLAZER CHEYENNE TRIM LEVEL



Available Cheyenne interior

All items in Custom Deluxe trim plus:

- Choice of two leather-grain vinyl trimmed front bucket seats in a choice of four colors or two custom cloth trimmed front bucket seats in either Blue or Saddle
- Center console with additional storage space

- Door and sidewall trim panels with simulated wood-grain trim plus map pockets in door panels
- Wood-grain vinyl trimmed instrument cluster with gauges
- Color-keyed front carpeting
- Black vinyl spare tire cover
- Available cloth seat trim in Saddle
- New front compartment headliner
- Hood and body-to-fender insulation.



Available Cheyenne exterior

All items in Custom Deluxe trim plus:

- Chromed front and rear bumpers
- Bright upper and lower body side and tailgate moldings
- Wheel opening moldings
- Bright brush-finished tailgate applique with Chevrolet nameplate
- Bright hubcaps and other accents
- Cheyenne exterior nameplates.

1977 CHEVROLET BLAZER EXTERIOR/INTERIOR COLORS

Please Note: Exterior and interior combinations shown in chart below are those recommended by Chevrolet; however, any exterior color combination may be ordered with any available interior color if the particular combination is desired by a customer.

SEAT TRIM			MODEL OPTION		COLORS AND ORDERING CODES					
					SEAT TRIM				HARDTOPS■	
Fabric	▲Code	Type	Custom Deluxe	Cheyenne Z84	Blue	Buckskin	Mandarin Orange	Red	White	Black
Standard Vinyl	V	Bucket	X		VDD2	VJU2	VMM2	VRR2	Z58	Z59
Custom Vinyl	W	Bucket	X	X	XDD2	XUU2	XMM2	XRR2		
Custom Cloth	H	Bucket		X	KDD2	KUU2				
♦ EXTERIOR COLORS			Primary	Secondary	RECOMMENDED INTERIOR TRIM COLORS					
BLACK MIDNIGHT			86	86	X	X	X	X	X	X
White Frost			86	12	X	X	X	X	X	X
BLUE, LITE (Light)			20	20	X				X	X
White, Frost			20	12	X				X	
BLUE, HAWAIIAN (Medium)			23	23	X				X	X
White, Frost			23	12	X				X	
BLUE, MARINER (Dark) (M)			25	25	X				X	X
White, Frost			25	12	X				X	
BROWN, CORDOVA (Dark) (M)			81	81		X	X		X	X
White, Frost			81	12		X	X		X	
BUCKSKIN			65	65		X	X	X	X	X
White, Frost			65	12		X	X	X	X	
GREEN, SEAMIST (Light) (M)			43	43		X			X	X
White, Frost			43	12		X			X	
MAHOGANY			76	76		X		X	X	X
White, Frost			76	12		X		X	X	
RED, CARDINAL (Medium)			70	70		X●		X	X	X
White, Frost			70	12		X●		X	X	
RED, METALLIC (Dark) (M)			71	71		X		X	X	X
White, Frost			71	12		X		X	X	
RUSSET METALLIC (M)			68	68		X	X		X	X
White, Frost			68	12		X	X		X	
SILVER, SARATOGA (M)			17	17	X			X	X	X
White, Frost			17	12	X			X	X	
TAN, SANTA FE			60	60		X	X	X	X	X
White, Frost			60	12		X	X	X	X	
WHITE, FROST			12	12	X	X	X	X	X	X
YELLOW, COLONIAL			53	53		X			X	X
White, Frost			53	12		X			X	

♦ Primary color shown in **BOLDFACE TYPE**; Secondary colors shown in Lightface Type. Two-tone paint not available with black top except when Midnight Black primary paint is ordered. ● Not recommended with code H trim.

▲ Seat Trim Codes: V—Plaid Pattern Vinyl; W—Buffalo Hide Vinyl; H—Plaid Pattern Cloth (M): Metallic

■ Cab roof painted with white textured paint when white top is ordered; with black textured paint when black top is ordered.

1977 CHEVROLET BLAZER VALUE FEATURES



All this included at no extra cost:

- Massive grille design—Efficient engine cooling
- Roof drip moldings—Direct water away from door openings
- Power-Beam single headlamps—Excellent night vision
- Wraparound painted front and rear bumpers—Good fender and rear body protection
- Amber bulb parking lamps—Clear vehicle identification
- Full front wheelhousings—For corrosion protection
- Double-wall hood and fender construction—Excellent rigidity
- Dual 16" electric 2-speed wipers—Large wipe area
- Dual-orifice windshield washer nozzles—Efficient coverage
- Flow-through power ventilation—Continuous inside air circulation
- Large windshield glass area—Excellent visibility
- Adjustable side-door ventipanes—Draft-free ventilation
- Wide-opening cab doors—Easy entrance or exit
- Keyless door locking—Easy vehicle locking
- Two-key system—Theft protection
- Bright exterior mirrors, both sides—Extra rear vision
- Permanent steel cab roof
- Removable fiberglass reinforced plastic top over cargo area
- Plastic top available with either white or black textured exterior paint finish
- Soft, vinyl-coated fabric top available in white, black, blue or buckskin
- Both tops include two large side windows
- Three interior lamps, coat hooks front and rear, tailgate with roll-up window (Removable plastic top only)
- Four cab-trim interior colors—Wide choice for customer preference
- Fully padded instrument panel—For safety and appearance
- Front-removable instrument cluster—Easy to service
- 15 exterior paint colors—Wide selection
- Wagon-type tailgate with manually retractable window glass—Easy access to load compartment. (Removable plastic top only.)

1977 CHEVROLET BLAZER CHASSIS VALUE FEATURES

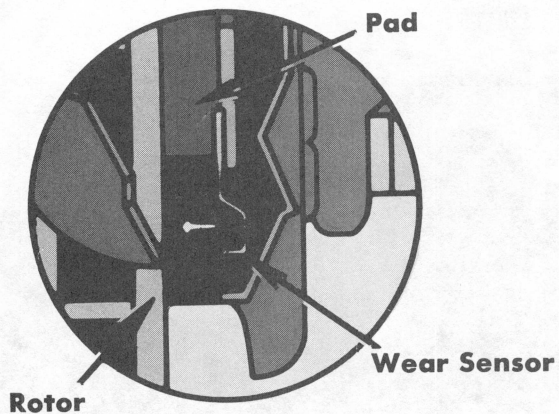

Front disc brakes • Resist fade • Recover quickly from water immersion • Lining wear sensor sounds audible signal when pads need replacement.

Rear brakes • Drum type • Finned for efficient cooling.

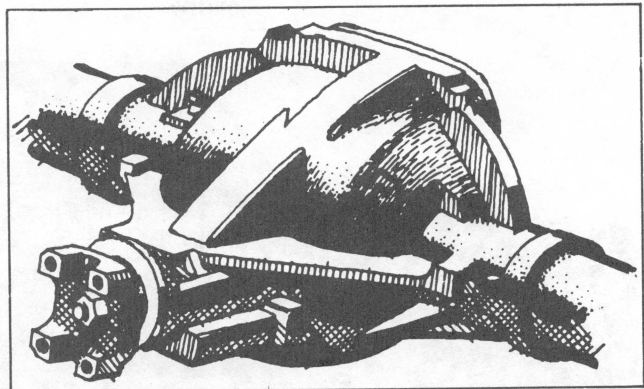

Salisbury rear axle • Inherently strong design • Large ring gear, tapered roller bearings, broad ratio coverage.

Vacuum power brakes • Standard on all Blazers.

Computer-selected brake systems • Brake components matched to GVW rating of vehicles • Proportioning valve balances front and rear braking forces.

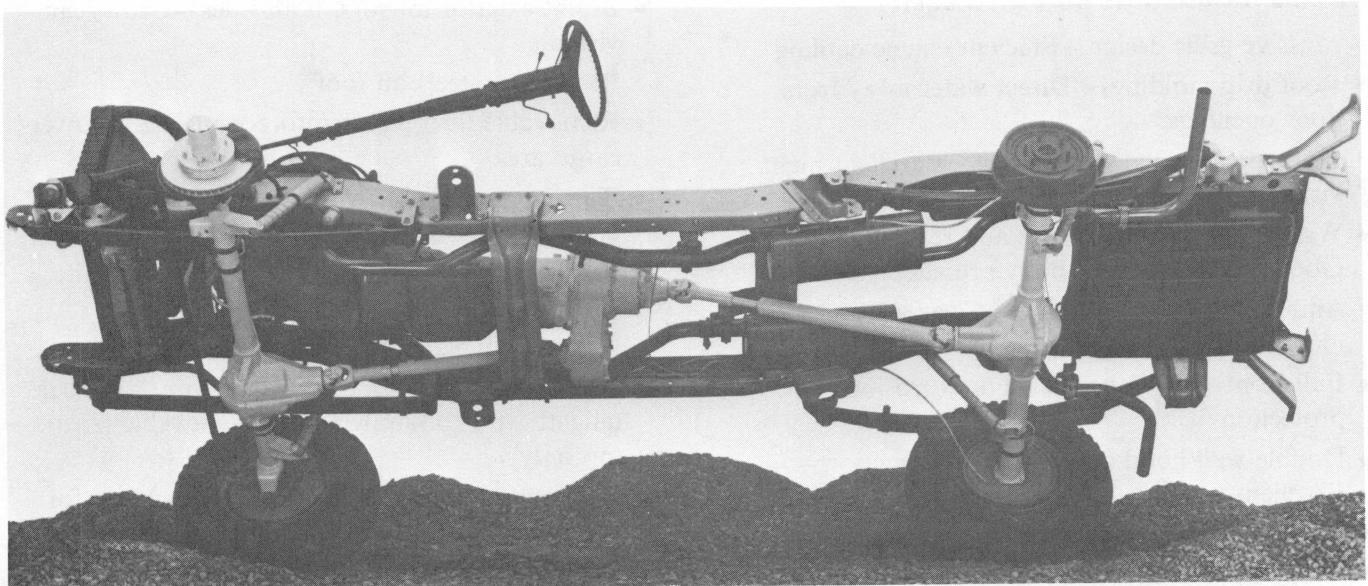

Energy-absorbing steering column • Designed to telescope inward • Provides cushioning in the event of severe frontal impact.

Tough ladder-type frame • Drop-center design for low cab mounting, low entry height • All-steel construction • Deep section channel side rails.

1977 CHEVROLET BLAZER VALUE FEATURES

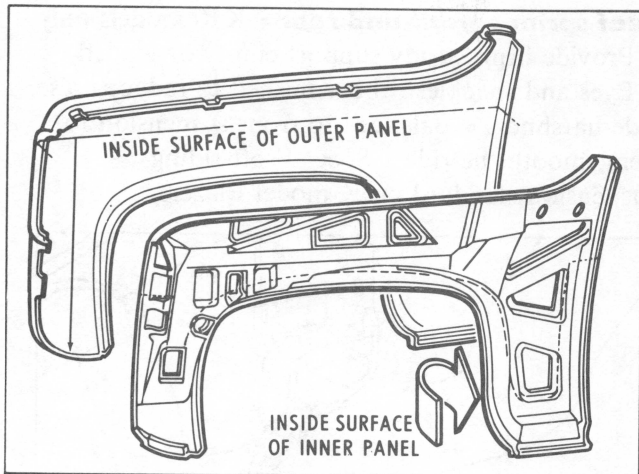

Improved rustproofing • Zinc-rich primer applied to front fender inner and outer panels before welding and final priming • Primer baked on inner surfaces of front door outer panels before forming and final priming • Entire body, doors and tailgate immersed in electrically charged primer.

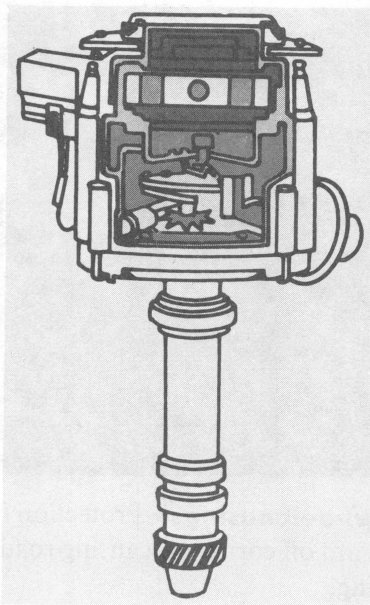

High Energy Ignition system • Standard on all engines, Sixes and V8s • Delivers up to 85% hotter spark than conventional systems • Improves cold-weather starting • Provides all-weather protection from moisture, dirt and road splash • Solid-state design eliminates ignition points and condenser, extends the time between recommended tune-ups.

Full-time 4-wheel drive standard with automatic transmission • Conventional 4-wheel drive standard with 3-speed or 4-speed manual transmission.

Three-speed manual transmission standard • Fully synchronized • Ruggedly built • Available: 4-speed manual, 3-speed Turbo Hydra-matic.

Low silhouette, high ground clearance

Series	Ground Clearance (in)★	
	Front	Rear
C10	7.0	6.6
K10	6.9	6.6

K10 Blazer suspension • Provides softer, more comfortable ride while retaining good off-road capability • Leaf-spring front suspension • Multi-leaf rear suspension (standard on all models).

Massive Girder Beam front suspension

• Standard, C10 Blazers • Friction-free coil springs are used.

Counter-angled rear shocks • One slants forward, the other aft • Mounting reduces brake and power hop.

Front disc brakes standard • Resist fading, recover quickly from effects of water immersion • Lining wear sensor gives audible signal when pads need replacing.

Rear drum brakes • Finned for cooling • Drum is shaped to keep dirt and water from linings.

Vacuum power brakes • Standard on all Blazers.

Front stabilizer bar • Standard on K10, available on C10 models.

GVW ratings • 6200 lbs. on K10 model • 6050 on C10 model.

1977 CHEVROLET BLAZER VALUE FEATURES

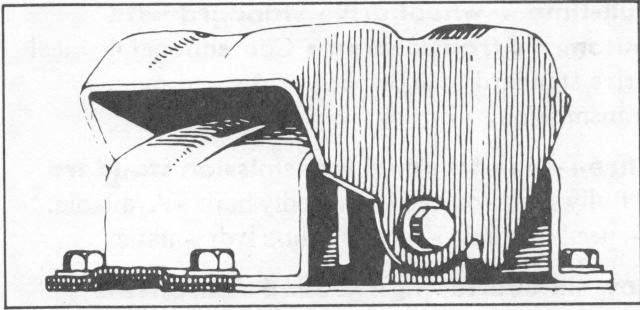

Engine mount design • Vibration-absorbing cushion between engine and frame • Front mounts have pre-loaded rubber cushion between steel backing plate and housing to absorb shocks.

Brake lines wire-covered in critical exposed areas • Protection against flying stones and gravel.

Sharp turning front axles • Easy to maneuver in tight places • Short curb-to-curb turning diameter.

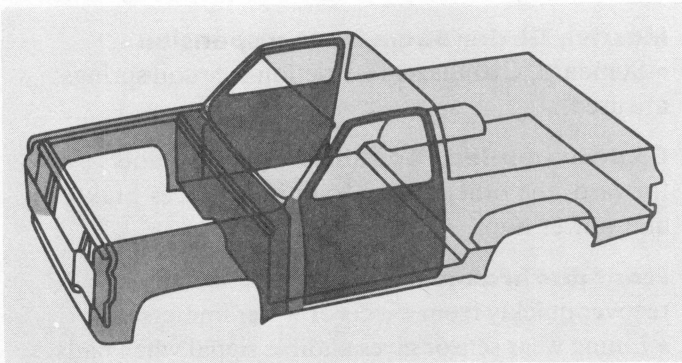

Corrosion protection in critical areas • Inside surfaces of front fender inner and outer panels are sprayed with anti-corrosion primer before welding and final priming • Radiator support lower reinforcement is made of zinc iron alloy steel • Outer surface of the support is sprayed with anti-corrosion primer before final priming • Primer is baked on the inner surface of the windshield frame and plenum panel assembly and on inner surfaces of front door outer panels before forming and final priming. Next, the entire Blazer steel body, doors and tailgate are totally immersed in electrically-charged primer—drawing paint into hidden seams and crevices for added corrosion protection. After the finish paint is applied and baked on, aluminum wax preservative is sprayed inside the plenum chamber, the door rocker panels and the lower portion of the doors.

Leaf springs front and rear • K10 models only
• Provide firm, steady support empty or loaded
• Eyes and shackles rubber-bushed to reduce noise, ride harshness • Balanced to front suspension to help smooth the ride • Special soft-riding suspension standard on K model Blazers.

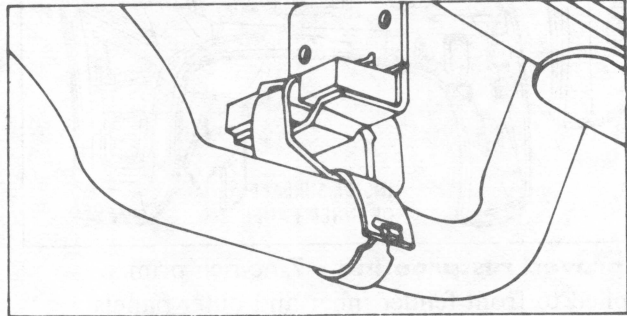

Compression-positioned exhaust hangers
• Permit unrestricted heat expansion • Improve isolation of exhaust system vibrations.

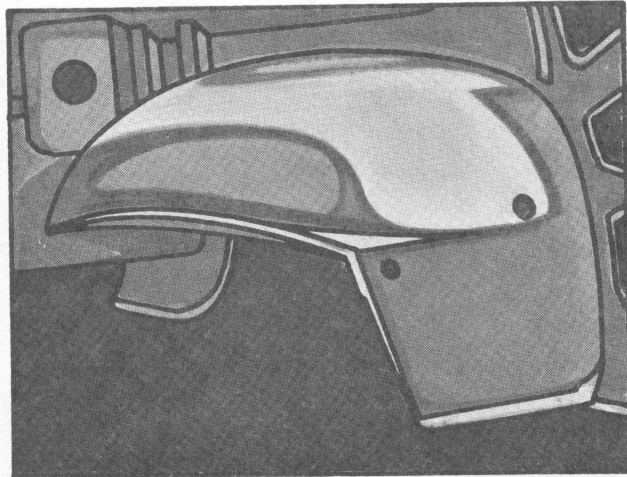

Full front wheelhousings • Protection from stone damage • Ward off corrosion-causing road splash
• Self-washing.

Front stabilizer bar • Standard on 4-wheel-drive models, available on 2-wheel-drive models
• Improves stability and driving ease.

1977 CHEVROLET BLAZER SPECIFICATIONS

Series	C10	K10
Engine Base Equip..... Clutch..... Air Filter..... Oil Filter..... Exhaust System..... Emission Control Systems.....	250 1-bbl L6 11", 124 sq. in. Oiled-paper Element Throwaway Type Single; Aluminized Meet Government Requirements	
Suspension, Front Type..... Axle Capacity..... Axle Ratio..... Springs @ Ground..... Shock Absorbers..... Stabilizer Bar.....	Independent Coil Springs 3250 lb. — 1625 lb. ea. 1" dia. —	Hypoid Driving Axle Leaf Springs 3600 lb. 4.11 1650 lb. ea. 1" dia. 1.25" dia.
Suspension, Rear Type..... Axle Capacity..... Axle Ratio..... Springs, Main @ Ground..... Shock Absorbers.....	Salisbury Axle; Hypoid Drive; Two-stage Multi-leaf Springs Leaf Springs 3750 lb. 4.11 1700 lb. ea. 1" dia.	
Brakes Front..... Rear..... Booster..... Parking.....	Hydraulic; Self-adjusting Disc; 11.86" Rotor Drum; 11.15" x 2.75" Dual Diaphragm Cable to Rear Wheels	
Electrical Battery..... Delcotron Generator.....	12 Volt; Negative Ground Freedom Type; 2500 watts @ 0°F. 37 amp.	
Frame Section Modulus.....	Carbon Steel; 39,000 psi 3.14	
Fuel Tank (nominal capacity)	25 gal.	
Steering Gear Type Linkage.....	Manual; Recirculating Ball Gear Parallelogram Conventional	
Transmission Shift Location.....	Fully Synchronized 3-Speed Steering Column	
Transfer Case Shift Lever..... PTO Opening.....	— — —	New Process 205 2-Speed Single Lever Left Side
Tires	(5) H78-15B (4PR)	
Wheels	(5) Disc 15" x 6"	

1977 CHEVROLET BLAZER—GVWR SELECTOR

GVW Rating (lbs)	†GAWR (lbs)		Minimum Equipment Required for GVW Rating		
			Tire Capacities (lbs ea)		Chassis Equipment
	Front	Rear	Front	Rear	
C10 SERIES					
6050	3220	3220	1610	1610	Standard
K10 SERIES					
6200	3220	3220	1610	1610	Standard

†GAWR's shown are the maximum for each axle with equipment listed. Other GAWR's are available, and they are determined as the minimum capacity of either axle, springs or tires.

FRONT AND REAR TIRE AVAILABILITY CHART

C-K10 SERIES

**Spare tire to match either front or rear tires must be ordered
K10 models require matching front and rear tread**

FRONT				REAR			
Capacity (lbs ea)	Description	Option Number		Capacity (lbs ea)	Description	Option Number	
		Highway	▲On-Off Road			Highway	On-Off Road
TUBELESS							
1610	H78-15B	HL	HR	1610	H78-15B	HL	HR
1610	H78-15B White Stripe	HM	—	1610	H78-15B White Stripe	HM	—
1760	10-15B	WR	—	1760	10-15B	WR●	—
1760	10-15B White Stripe	WS●	—	1760	10-15B White Stripe	WS●	—
1790	L78-15B	LB	LC	1790	L78-15B	LB	LC
1790	L78-15B White Stripe	LD	—	1790	L78-15B White Stripe	LD	—
1905	LR78-15C Radial White Stripe	CD	—	1905	LR78-15C Radial White Stripe	CD	—
TUBE-TYPE							
1610	6.50-16C	MG	—	1610	6.50-16C	MG	—
1720	7.00-15C	NH	—	1720	7.00-15C	NH	—
1800	7.00-16C	NK	NL	1800	7.00-16C	NK	NL

▲On-Off road front tires available on K10 models only.

● Available on K10 models only.